

RUBICON

Lil' Wonder
Lil' Wonder4
Lil' Wonder5

Power Amplifiers

Owner's Manual
and
Installation Guide



Lil' Wonder

SOUNDSTREAM

Congratulations

Thanks for buying Soundstream's **Lil' Wonder**, **Lil' Wonder4**, or **Lil' Wonder5**. We have always been known for amazing high-end power plants, and to show our flexibility and versatility we make great equipment like this. Your new amp has been designed to give you the "most performance available in the smallest package possible." Hence the name **Lil' Wonder!** Pound for pound and inch for inch these are some of the strongest amps ever made.

The **Lil' Wonder**, **Lil' Wonder4**, and **Lil' Wonder5** are the ideal amps for almost any configuration. They have the power to run front speakers, rear fill, a center channel, or even more importantly, giant subwoofers. Don't let their compact sizes fool you, you'll be amazed by the power. They have all of the technological advantages of their big Rubicon brothers, like a RUBI™ power supply and STACT™ architecture. To get the most performance out of your system, you'll need to read this entire manual. It is the only way to learn about all of the **Lil' Wonders'** capabilities and features. Please keep this manual and your sales receipt for future reference.

These gutsy amplifiers, like all Soundstream amplifiers, are the result of American innovation and the highest quality control standards. When properly installed, they will provide you with many years of listening pleasure. Just in case someone "borrows" your amplifier with no intention of returning it, fill in the blanks below and stash them away in your permanent records. It will help to protect your investment. Once you have done that, you're ready to rock. So hook it up, crank it up, and be amazed by your new **Lil' Wonder**, **Lil' Wonder4**, or **Lil' Wonder5**.

Model and Serial # _____

Dealer's Name _____

Date of Purchase _____

Installation Shop _____

Installation Date _____

CAUTION!

Prolonged listening at high levels may result in hearing loss. Even though your new Soundstream Rubicon amplifier sounds better than anything you've ever heard, exercise caution to prevent hearing damage.

Table of Contents

| | |
|---|-----------|
| Design Features | p 4 - 5 |
| Callouts for the Lil' Wonder | p 6 - 7 |
| Callouts for the Lil' Wonder4 | p 8 - 9 |
| Callouts for the Lil' Wonder5 | p 10 - 11 |
| Crossover Adjustments | p 12 |
| Hawkins Bass Control™ Theory and Use | p 13 |
| Wiring | p 14 - 15 |
| Installation and Mounting | p 16 |
| Level Setting, Trident Protection Circuitry, and Front Spoiler. ... | p 17 |
| Sample Systems | p 18 - 23 |
| Troubleshooting | p 24 |
| Service | p 24 |
| Specifications | p 25 - 27 |

Design Features

- **RUBI™ Power Supply** (Rapid-Used Branching Impulse) Our new power supply eliminates "power sags" during low frequency reproduction by rapidly increasing the duty cycle, stabilizing the power supply and allowing it to deliver the power required when reproducing low frequencies. Also, greater reserve gate power is now stored for low voltage conditions that occur during extreme conditions.
- **STACT™** (Stabilized Apex Current Topology) Reduces power supply stress by 50%. Use of inverted channels usually degrades the stereo image due to phase reversal of even order harmonic distortion that occurs between the inverted channels. In the STACT design inversion is done at the power amplifier drive stage. Since the fully symmetrical power amplifier produces no even harmonic distortion itself and all preamp circuitry (which does produce even harmonics) is run completely in phase, no even harmonic distortion phase reversal occurs.
- **Trident™ Protection** Three types of protection for RUBICON amplifiers:
 1. Output protection against short circuits or improper loads.
 2. Ground fault detection shuts down the amplifier when a significant (5 volt or greater) voltage fluctuation occurs between audio ground and battery ground.
 3. Thermal protection will shut the amplifier down in extreme thermal conditions.
- **Hawkins Bass Control** Provides focused subwoofer boost and routes wasted subsonic power to the audible bandwidth. The **Lil' Wonders** contain the fixed Hawkins Bass Control which allows you to boost bass 6dB at 45Hz. A built-in subsonic filter at 13Hz helps protect the speakers.
- **Harmonic Bass Alignment™** The 2nd and 3rd order harmonic peaks are critically aligned to fundamental peaks at low frequencies. This produces tighter, more accurate bass reproduction.
- **Drive Delay II Muting™** Amplifier section now powers up 2 - 3 seconds after power supply, eliminating turn on pops. Turn off process is reversed. Amplifier section turns off first, followed by power supply.
- **Dynamically Optimized Power Grid™** Power grid is now evenly distributed between primary and secondary power supplies, providing greater dynamics and improved RF filtering.

- **Chassisink™** All power transistors are sandwiched between the circuit board and the heatsink to provide cool efficient amplifier operation in a smaller package.
- **Continuously Variable Low Pass Crossover Networks (Lil' Wonder4 and Lil' Wonder5)** 12dB/oct Lowpass crossover variable from 55 to 220Hz.
- **Built-in Staggered S.I.P. Crossover Networks** Built-in two-way electronic crossover is designed to send either high or low pass information to the amplifier with a 12dB/oct slope (Highpass only on the **Lil' Wonder4** and **Lil' Wonder5**).
- **Flexible Input Level Control** 200mV to 5V input sensitivity. Stereo level control allows user to optimize system level control.
- **Symmetrical Discrete Balanced Class A Drive Boards** Auto-adjusts for linear performance in low impedance loads.
- **Removable Front Spoiler** Allows for stealth installation of RCA, Speaker and Power wiring.

Callouts for the Lil' Wonder

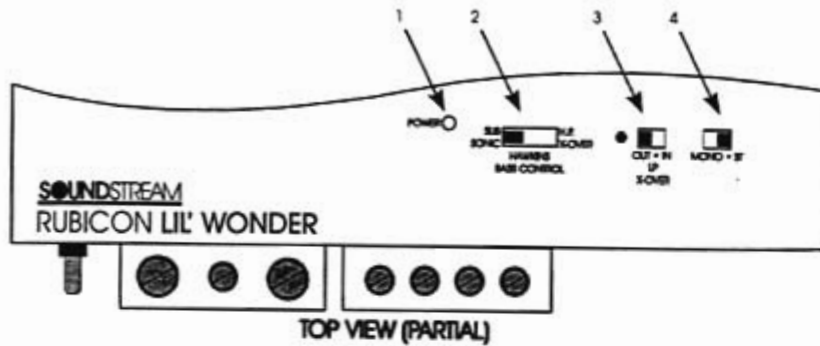

1. **Power LED** - Indicates amplifier power.
2. **Subsonic, Hawkins Bass Control, H.P. XOVER Switch** - Selectable high pass filter frequency range. Select "SUB SONIC" to engage the Sub Sonic filter at 13Hz with no boost. Select "Hawkins Bass Control" to engage the Sub Sonic filter at 45 Hz with a +6dB boost. Select "H.P. XOVER" to engage the amplifier's high pass filter at 45Hz or 150Hz (depending on S.I.P.'s) for running satellite speakers.
3. **Low Pass XOVER Switch** - Selectable low pass filter for driving subwoofers at 90Hz. *Note: Do not have the "L.P. XOVER" and the "H.P. XOVER" engaged at the same time except for bandpass operation.*
4. **MONO/ST Switch** - Select "MONO" for bridged mono operation with a single input signal (right channel only). Select "ST" for normal stereo operation.

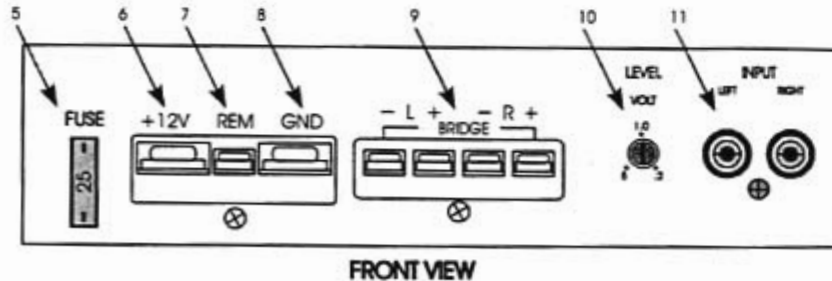

5. **FUSE** - Main power supply fuse. *Warning: Replace only with the same value fuse!*

Callouts for the Lil' Wonder

6. **+12V** - Connected to a fuse or circuit breaker, then to the battery's positive terminal.
7. **REMOTE** - Remote turn-on input from the head unit. Accepts +12V.
8. **GND** - Main ground connection. Bolt to a clean chassis point in the vehicle.
9. **Speaker Connection Terminal** - Speaker connections for channels 1&2.
10. **Input Levels** - Stereo input level control.
11. **RCA Inputs** - Right and Left channel RCA inputs.

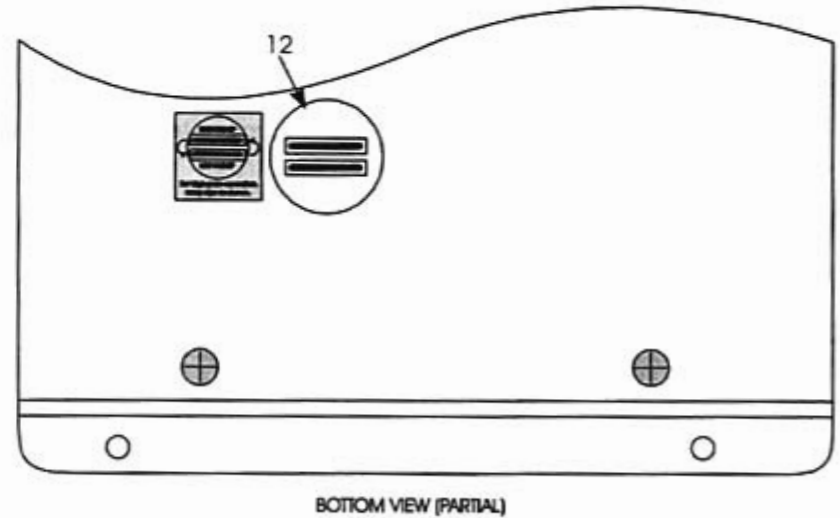

12. **Crossover S.I.P.'s** - Crossover frequency settings for amplifier.

Callouts for the Lil' Wonder4

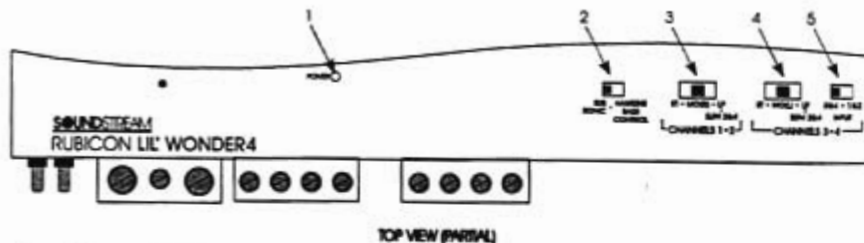

TOP VIEW (PARTIAL)

1. **Power LED** - Indicates amplifier power.
2. **Subsonic / Hawkins Bass Control Switch** - Select "Subsonic" to engage the Subsonic filter at 13Hz. Select "Hawkins Bass Control" to engage the +6dB boost @ 45 Hz for the lowpass channel.
3. **ST/MO(R)/LP Switch** - "ST" for normal stereo operation. "MO" for bridged mono operation with a single input signal (right input only). "LP" for low pass bridged mono operation with input from channels 3&4.
4. **ST/MO(L)/LP Switch** - "ST" for normal stereo operation. "MO" for bridged mono operation with a single input signal (left input only). "LP" for low pass bridged mono operation with input from channels 3&4.
5. **Input Selection Switch** - Selectable inputs from internal (channels 1&2) or external (channels 3&4).

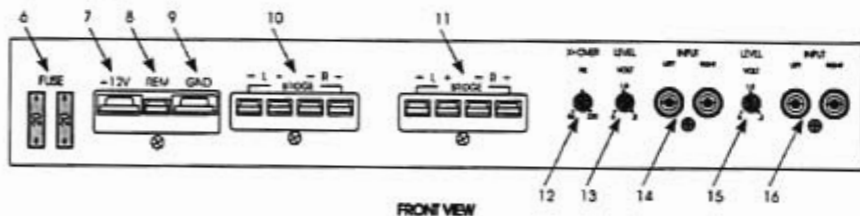

FRONT VIEW

6. **Fuse** - Main power supply fuse. *Warning: Replace only with the same value fuse!*
7. **+12V** - Connected to a fuse or circuit breaker, then to the battery's positive terminal.
8. **Remote** - Remote turn-on input from the head unit. Accepts +12V.
9. **GND** - Main ground connection. Bolt to a clean chassis point in the vehicle. 1&2.

Callouts for the Lil' Wonder4

10. **Speaker Connection Terminal** - Speaker connections for channels 1&2.
11. **Speaker Connection Terminal** - Speaker connections for channels 3&4.
12. **Low Pass Filter Control Adjustment** - Crossover frequency control for the internal low pass filter.
13. **Input Levels** - Stereo input level control for channels 1&2.
14. **RCA Inputs** - Right and Left channel RCA inputs for channels 1&2.
15. **Input Levels** - Stereo input level control for channels 3&4.
16. **RCA Inputs** - Right and Left channel RCA inputs for channels 3&4.
17. **Crossover S.I.P.'s** - Crossover frequency settings for amplifier.

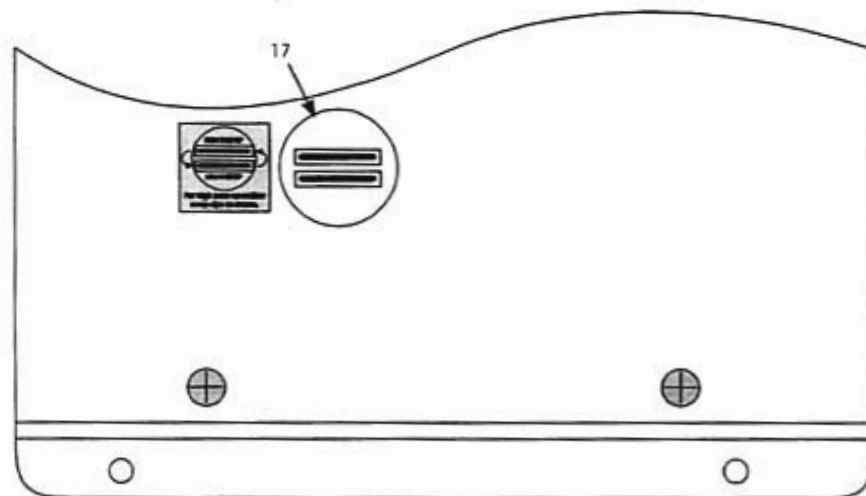

BOTTOM VIEW (PARTIAL)

Callouts for the Lil' Wonder5

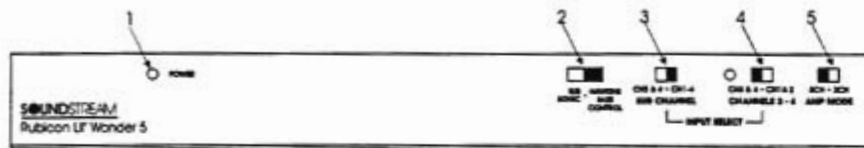

TOP VIEW (PARTIAL)

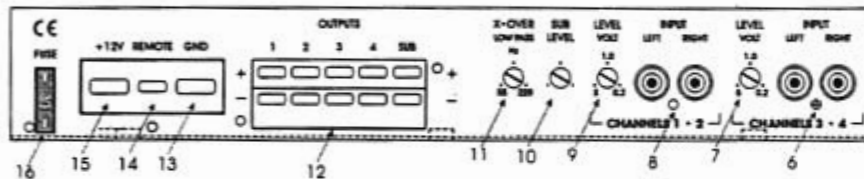

FRONT VIEW

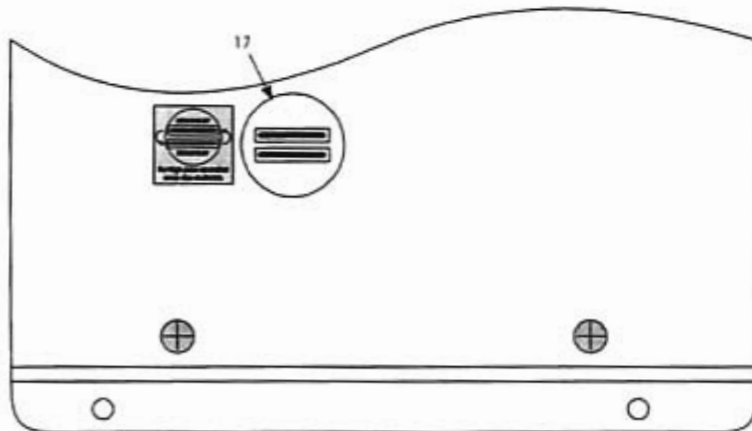

BOTTOM VIEW (PARTIAL)

Callouts for the Lil' Wonder5

1. **Power LED** - Indicates amplifier power.
2. **Subsonic / Hawkins Bass Control Switch** - Select "SUB SONIC" to engage the Sub Sonic filter at 13 Hz. Select "HAWKINS BASS CONTROL" to engage the subwoofer channel's high pass filter @ 45 Hz with +6 dB boost for optimum bass.
3. **Subwoofer Channel Input Select** - Selectable inputs; "CH 1-4" for non-fading bass control, "CH 3&4" for front to rear fading bass control.
4. **Channels 3&4 Input Select** - Selectable inputs from internal (CH 1&2) or external (CH 3&4 local RCA inputs).
5. **Amp Mode Switch (Channels 1-4)** - Select "3CH" for bridged mono output in 3 channel operation (use input channels 1 & 2). Select "5CH" for stereo output in 5 channel operation.
6. **Inputs** - Right and left channel RCA inputs for channels 3&4.
7. **Input Level** - Channels 3&4 input level control.
8. **Inputs** - Right and left channel RCA inputs for channels 1&2.
9. **Input Level** - Channels 1&2 input level control.
10. **Sub Input Level** - Subwoofer channel input level control.
11. **Low Pass Filter Control Adjustment** - (Subwoofer Channel) cross-over frequency control for the internal low pass filter.
12. **Speaker Connection Terminal** - Speaker connections for CH 1-4 & Subwoofer Channel.
13. **GND** - Main ground connection. Bolt to a clean chassis point in the vehicle.
14. **REMOTE** - Remote turn-on input from the head unit. Accepts +12V.
15. **+12V** - Connected to a fuse or circuit breaker, then to the battery's positive terminal.
16. **Main Fuse** - Main power supply fuse.
17. **Crossover S.I.P.'s** - Crossover frequency settings for amplifier.

Crossover Adjustments for the Lil' Wonder

CROSSOVER

In most car audio installations, there is a tendency for a "midbass boom." Because of their interior dimensions, most cars will resonate or ring at these midbass frequencies. If we design the system so there is reduced output information in this region, the final response is very smooth and natural sounding.

CHANGING FREQUENCIES

The **Lil' Wonder** comes with a 90Hz Low Pass S.I.P. and a 45Hz Hawkins and High Pass S.I.P. (Series In-line Package resistor network). If you are using this amplifier in the Low Pass Configuration, you will not need to change the S.I.P. crossover. If you are using the amplifier in a **High Pass** configuration we recommend that you use a higher frequency (150Hz) for your crossover. *In order to receive a higher crossover point, remove the factory Low Pass S.I.P. (The S.I.P. with the white dot), and the factory High Pass/Hawkins S.I.P. out of the amplifier. Place the S.I.P. with the white dot in the socket for High Pass/Hawkins. This will give a High Pass frequency of 150Hz.* Then place the remaining S.I.P. in the Low Pass socket. **Make Sure That the Low Pass Crossover is NOT Engaged while the High Pass crossover is engaged, unless a bandpass x-over is desired.** If you want to use a frequency other than the factory pre-set frequencies follow the chart or the formula below to select your own crossover points.

The **Lil' Wonder4** and **Lil' Wonder5** uses the same S.I.P.'s for High Pass (factory set at 150 Hz) and Hawkins as the **Lil' Wonder**. However, the Low Pass is adjusted using a 12dB/oct variable crossover that has a range of 55 to 220 Hz. **On the Lil' Wonder amplifiers a full range signal can be achieved by removing the S.I.P.'s entirely.**

| SIP (K _Ω) | LP (Hz) | HP (Hz) |
|-----------------------|---------|---------|
| 180 | NA | 22 |
| 120 | NA | 25 |
| 82 | NA | 33 |
| 62 | NA | 39 |
| 47 | 23 | 47 |
| 43 | 25 | 50 |
| 30 | 36 | 66 |
| 22 | 49 | 86 |
| 15 | 71 | 120 |
| 12 | 89 | 146 |
| 8.2 | 130 | 208 |
| 4.7 | 228 | 353 |
| 3.3 | 324 | 498 |
| 2 | 535 | 813 |

NOTE: The following formulas may be used to determine values in creating custom resistor packs.
 The Low Pass frequency is equal to 1,070,000 divided by the individual resistor value, or $1,070,000 / R \text{ ohms} = X \text{ Hz}$
 Example: $1,070,000 / 12,000 = 89 \text{ Hz}$
 The High Pass frequency is equal to 1,600,000 divided by the individual resistor value plus 13, or $(1,600,000 / R \text{ ohms}) + 13 = X \text{ Hz}$
 Example: $(1,600,000 / 12,000) + 13 = 146 \text{ Hz}$
 To make a custom S.I.P., use 4 identically valued resistors 5% or higher tolerance. See the drawing of the S.I.P. for more information.

Hawkins Bass Control - Theory and Use

Hawkins Bass Control (fixed) is a unique subwoofer control circuit included with the Soundstream **Lil' Wonder** amplifiers. It is capable of removing subsonic energy in program material below 45 Hz at 12 dB/Octave, while boosting subwoofer frequencies by +6dB. Once you engage the switch, you engage a subsonic (High Pass) filter at 45 Hz, with a +6dB boost at 45 Hz.

Application

Subwoofer drivers in general have excellent power handling characteristics over their operational bandwidth. This bandwidth is determined by many factors, including driver design, and enclosure type. It is possible to overdrive any subwoofer driver by sending powerful signals outside of its operational bandwidth. These potentially damaging signals can be removed by adding a subsonic filter. Figure 1 shows the effectiveness of the Hawkins Bass Control on woofer excursion in a vented enclosure. The woofer travels 7.5 mm at 10 Hz. With Hawkins Bass Control properly adjusted, this excursion can be reduced to less than 1 mm. This is of great benefit to lowering woofer distortion and increasing output.

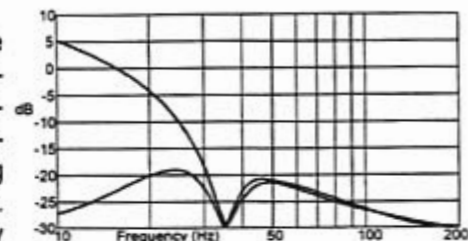

FIG. 1 Limited Excursion

With Soundstream's Hawkins Bass Control, the boost and frequency control can provide the "tailoring" needed for any type of "assisted" design and any woofer in any type of installation.

Wiring

POWER AND GROUND

To ensure maximum output from your RUBICON Lil' Wonder amplifier, use high quality, low-loss power and ground cables and connections. The Lil' Wonder amplifiers will accept up to 8 gauge power and ground cables. Determine from the chart below the minimum gauge power and ground wire for your application.

| | <i>up to 10'</i> | <i>up to 20'</i> |
|---------------------|------------------|------------------|
| <i>Lil' Wonder</i> | 8 or 10 gauge | 8 gauge only |
| <i>Lil' Wonder4</i> | 8 or 10 gauge | 8 gauge only |
| <i>Lil' Wonder5</i> | 8 or 10 gauge | 8 gauge only |

CIRCUIT BREAKERS AND FUSES

EXTERNAL

Like all audio components, the Lil' Wonders must be fused near the battery. A fuse or circuit breaker must be located within 18" of the battery. This will prevent a fire in the event of a shorted cable. See the chart below to determine the correct fuse value.

INTERNAL

The Lil' Wonder amplifiers are fused with automotive-type fuses. In the event of a blown power supply fuse, replace with the correct value fuse found in the chart below. **Never replace the fuse with a higher value than what is supplied. This may result in amplifier damage and will void the warranty!**

RUBICON Amplifier Fuse Values

| | <i>Amplifier Fuse</i> | <i>Battery Fuse / Circuit Breaker</i> |
|---------------------|-----------------------|---------------------------------------|
| <i>Lil' Wonder</i> | 25 amp automotive | 30 amp |
| <i>Lil' Wonder4</i> | (2) 20 amp automotive | 40 amp |
| <i>Lil' Wonder5</i> | 30 amp automotive | 40 amp |

REMOTE TURN-ON

Connect the "Remote" line to the turn-on lead from the source unit. When +12 Volts is received, the amplifier will turn on.

Wiring

SIGNAL CABLE

Use a high quality cable that will be easy to install and has minimal signal loss to guarantee optimum performance.

SPEAKER CABLE

The Lil' Wonder amplifiers will accept up to 12 gauge speaker cable. Use a high quality, flexible, multi-strand cable for best performance and longevity.

INSTALLATION AND MOUNTING

AMPLIFIER LOCATION

The Lil' Wonder amplifiers employ highly efficient circuitry, a custom-engineered heat sink, and a unique Chassisink construction to maintain lower operating temperatures. Additional cooling may be required if the amplifier is located in a tightly confined area or when driving especially low impedance loads at extremely high levels.

When mounting the amplifiers, they should be securely mounted to either a panel in the vehicle or an amp board or rack that is securely mounted to the vehicle. The mounting location should be either in the passenger compartment or in the trunk of the vehicle, away from moisture, stray or moving objects, and major electrical components. To provide adequate ventilation, mount the amplifier so that there are at least two inches of freely circulating air above and to the sides of it.

MOUNTING THE AMPLIFIER

- Using the amplifier as a template, mark the holes on the mounting surface.
- Remove the amplifier and drill the holes for the mounting screws.
- Secure the amplifier to the mounting surface using the supplied hardware.

WIRING

- Run and connect the audio signal and remote turn-on cables to the amplifier from the source unit.
- Carefully run the positive cable from the amplifier to a fuse or circuit breaker within 18" of the battery.
- Connect the fuse or circuit breaker lead to the battery. Leave the circuit breaker off or the fuse out until everything is bolted down.
- Secure the ground cable to a solid chassis ground on the vehicle. It may be necessary to sand paint down to raw metal for a good connection.
- Double check each and every connection!
- Re-connect the fuse or circuit breaker.

POWER UP

Power up the system, there may be a 2-3 second delay from the time the source unit is turned on to the time that the amplifier turns on, which is normal. Once the amplifier LED is on and the source unit is playing, you should have sound coming from the speakers.

LEVEL SETTING

The input levels are adjusted by means of the stereo channel input level control located on the front of the amplifier.

In the ideal situation, all components in the audio system reach maximum undistorted output at the same time. If you send a distorted signal to an amplifier, it is simply going to amplify distorted information. The same holds true if an outboard processor or crossover begins to distort before you have maximum output from the amplifier. By setting all components to reach clipping at the same time, you can maximize the output of your system. For the RUBICON amplifiers, follow these steps for setting the input levels:

- Turn the amplifier's input level to minimum position (counter-clockwise).
- Set the source unit volume to approximately 3/4 of full volume.
- While playing dynamic source material, slowly increase the amplifier's input level until a near maximum undistorted level is heard in the system.

FRONT SPOILER

Once the amplifier is installed and the proper levels set, place the front spoiler in position, and bolt it on using the supplied hardware.

Trident Protection Circuitry

Your Lil' Wonder amplifier is protected against both overheating and short circuits by means of main power supply fuses and the following circuits:

- ◆ Speaker output protection
- ◆ Ground fault protection
- ◆ A failsafe thermal protection circuit

NOTE: *If you experience blown main power supply fuses, it is likely that the amplifier is seeing a dead short, either in the speaker wire or in the speaker itself. Rectify the problem before blowing multiple fuses! DO NOT increase values beyond the original fuse value! Doing so will void your warranty and may damage your amplifier.*

Lil' Wonder Sample Systems

2 channels of input
2 channels of stereo high pass output

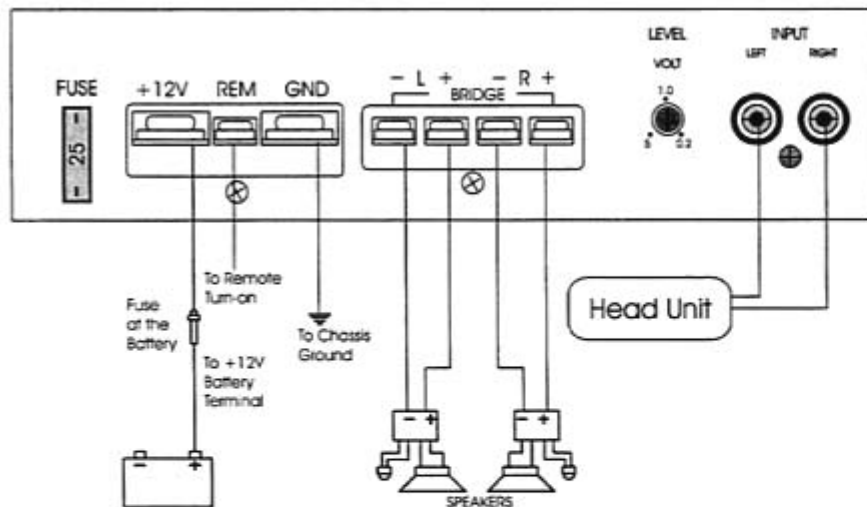
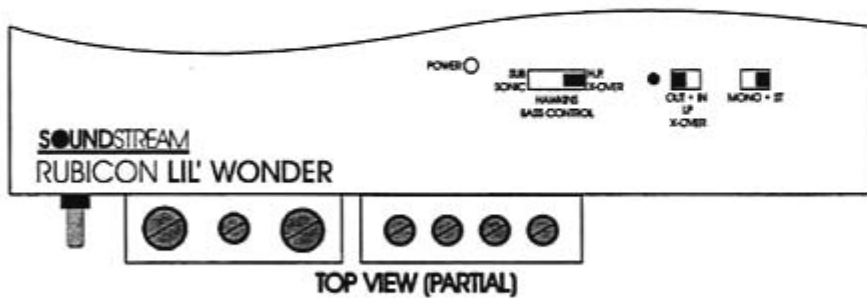

Lil' Wonder Sample Systems

1 channel of input
1 mono channel of low pass output

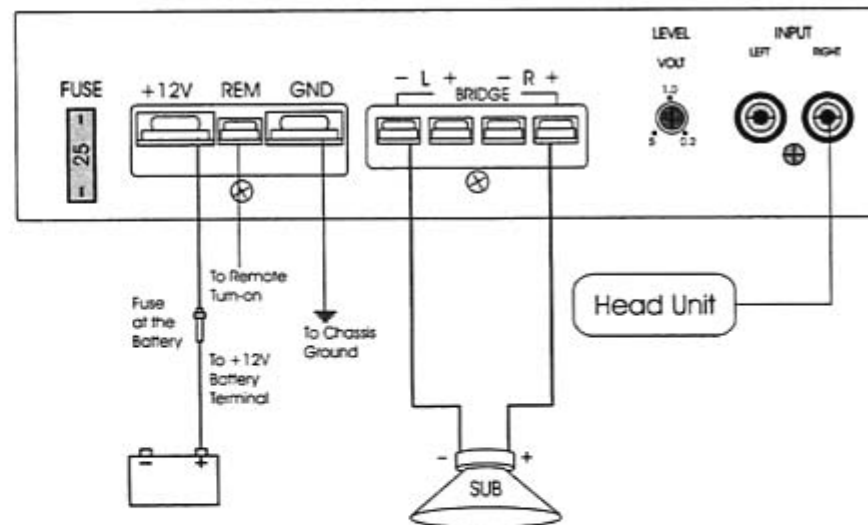
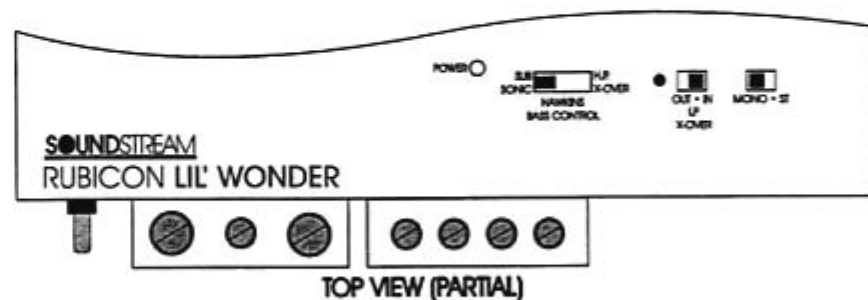

Lil' Wonder4 Sample Systems

4 channels of input
4 channels of stereo high pass output

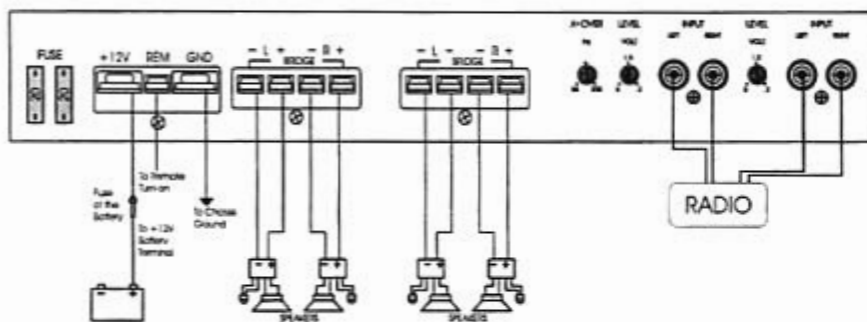
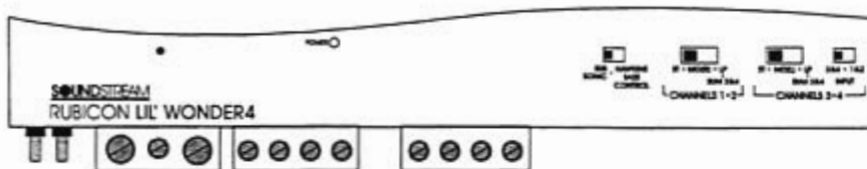

Lil' Wonder4 Sample Systems

4 channels of input
2 channels of stereo high pass output
1 mono channel of low pass output

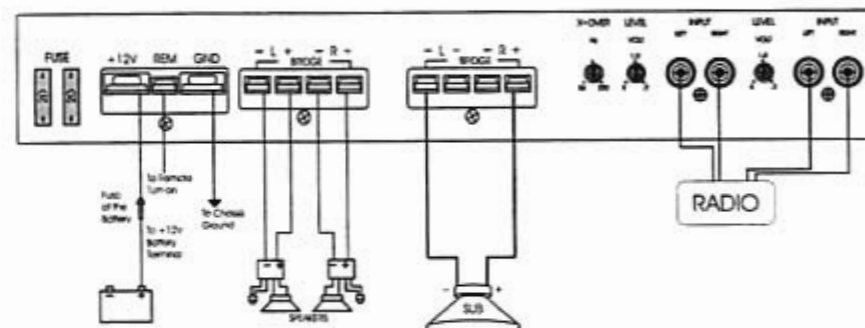
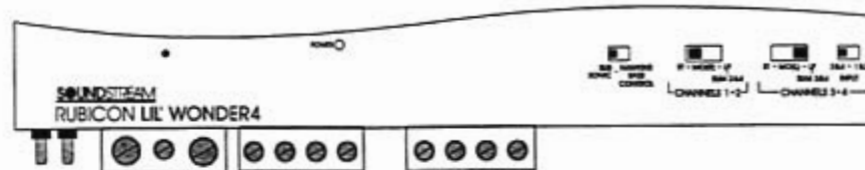

Lil' Wonder5 Sample Systems

4 channels of input
 4 channels of stereo high pass output
 1 mono channel of low pass output

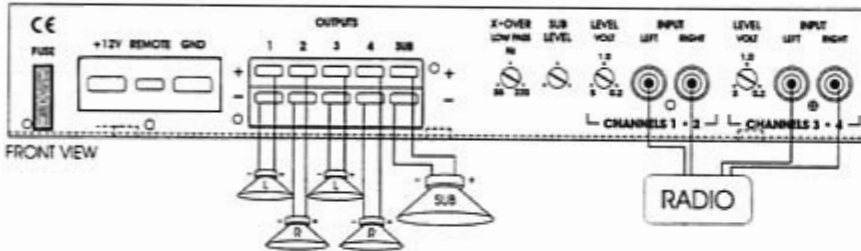

Lil' Wonder5 Sample Systems

4 channels of input
 2 channels of stereo high pass output
 1 mono channel of low pass output

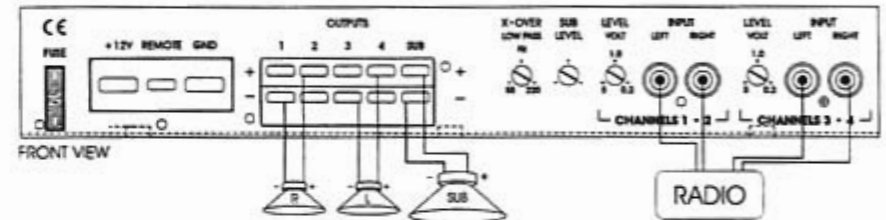

Troubleshooting

| <i>PROBLEM</i> | <i>CAUSE</i> |
|---|---|
| No Sound and power LED is not lit | <ol style="list-style-type: none"> 1. No power or ground at the amp 2. No remote turn-on signal 3. Blown fuse near the battery |
| No sound, power LED is lit | <ol style="list-style-type: none"> 1. No signal input 2. Speaker leads may be shorted 3. Speaker leads may be referenced to ground |
| Amplifier output cuts on/off repeatedly | <ol style="list-style-type: none"> 1. Speaker output may be shorted to ground. 2. Speaker leads may be shorted to each other. Check continuity with a volt meter. |
| Repeatedly blow amp fuse; frequent activation of Trident protection or Smart Power Supply Circuit | <ol style="list-style-type: none"> 1. Speaker or leads may be shorted 2. Amplifier load may be too low 3. Verify adequate amp ventilation |

Service

Your Soundstream RUBICON amplifier is protected by a limited warranty. Please read the enclosed warranty card for details and send it in.

Specifications for the Lil' Wonder

Power (4 ohm, 12.6v)
 Power (2 ohm, 12.6v)
 Power (2 ohm, 14.4v)
 Power (4 ohms bridged, 14.4V)
 Maximum rated power
 Crossover
 Damping
 Frequency response
 Color Factor
 Hawkins Bass Control

 Input sensitivity

 Piercings
 Shape bias
 Signal to Noise
 Stereo separation

 THD
 Dimensions

Lots!
 More!
 Even more!
 Huge!
 NC-17
 Up and Down
 Wet, very wet
 Flatter than a board
 Blue
 2 settings: Bass! And More Bass!
 Don't worry, you can't offend it
 Forty
 100%
 Foghorn to a dead monkey
 Legally, but still see each other on Fridays
 You can't hear it
 36" x 24" x 36"
 (just kidding, 7" x 11 3/8" x 2 1/4")

Specifications for the Lil' Wonder4

| | |
|----------------------|--|
| Power (4 ohm, 12.6v) | Super! |
| Power (2 ohm, 12.6v) | Super + 3dB! |
| Power (2 ohm, 14.4v) | Teeming! |
| Maximum rated power | Insane! |
| Crossover | Swings both ways |
| Damping | Very, very moist |
| Frequency response | Flatter than a 4 day old beer |
| Color Factor | Rubicon Blue |
| Hawkins Bass Control | 2 settings: Bass! and More Bass! |
| Input sensitivity | Fully Aware |
| Piercings | Forty-nine |
| Shape bias | 100% |
| Signal to Noise | Hullabaloo to a sleeping monkey |
| Stereo separation | About 9 feet 6 9/32 inches |
| THD | You can't hear it |
| Dimensions | Parallel (just kidding, 11" x 11 3/8" x 2 1/4") |

Specifications for the Lil' Wonder5

| | |
|----------------------|---|
| Power (4 ohm, 12.6v) | 4 x Gobs plus 1 x Mucho |
| Power (2 ohm, 14.4v) | 4 x Armageddon plus 1 x Red October |
| Maximum rated power | 46DD |
| Crossover | Both ways – some up and some down |
| Damping | Freakin' control monster |
| Frequency response | Flatter than a bug on a windshield |
| Color Factor | Four |
| Hawkins Bass Control | 2 settings: Bass! and More Bass! |
| Input sensitivity | Fingertip |
| Piercings | Forty-six |
| Shape bias | No |
| Signal to Noise | Pandemonium to a sobbing monkey |
| Stereo separation | 3 time zones |
| THD | You can't hear it |
| Dimensions | Forty-six (just kidding, 11" x 11 3/8" x 2 1/4") |